

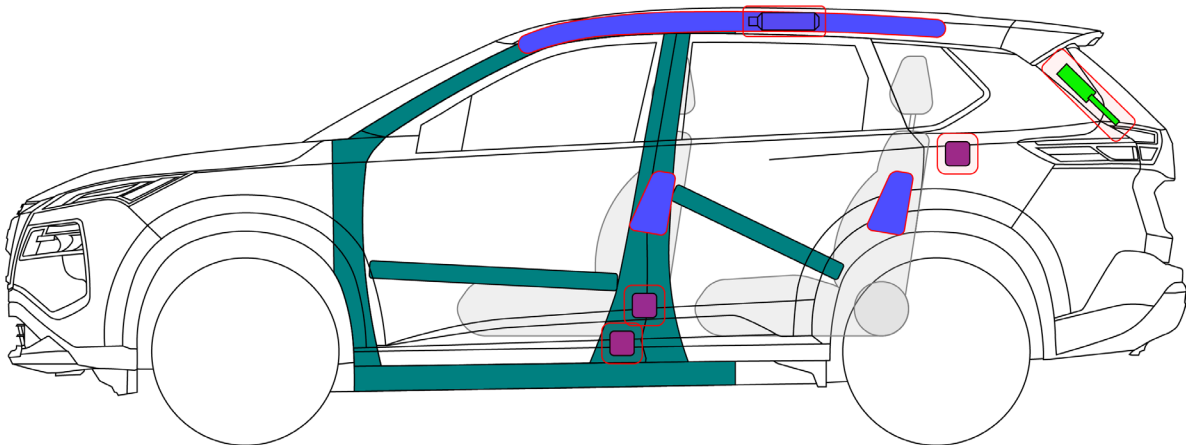

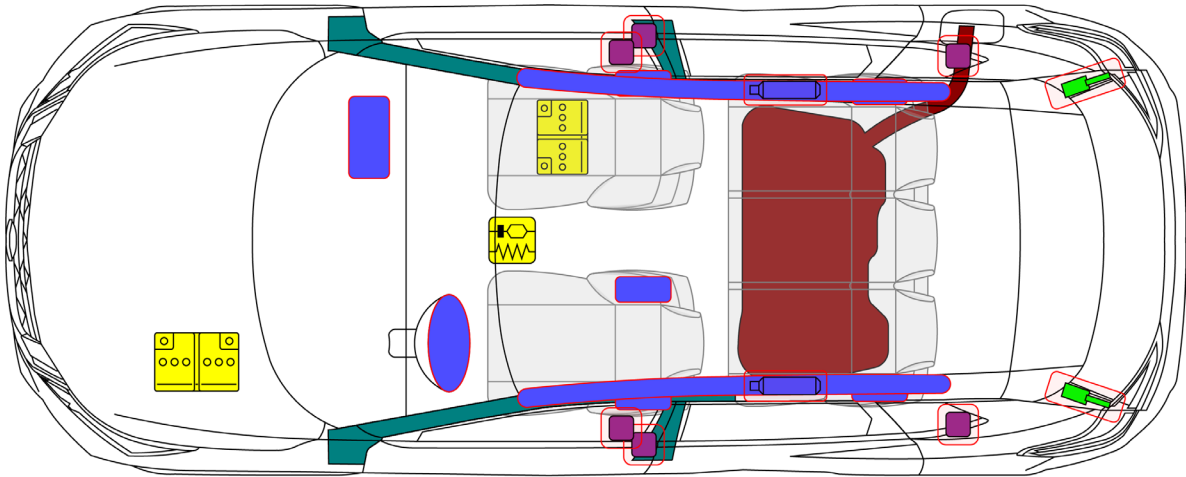







Nissan X-Trail

TYPE: T33, 5-door SUV
(2022 -)



 Airbag	 Dispozitiv de umflare cu gaz stocat	 Sistem de pretensionare a centurilor de siguranță	 Unitate de control SRS	 Baterie joasă tensiune
 Tijă de gaz / arcuri preîncărcate	 Zonă de rezistență mare	 Conținutul rezervorului de combustibil benzină/etanol		

1. Identificare / recunoaștere

Logo-ul mărcii



Numele modelului



Capac de combustibil



2. Imobilizare / stabilizare / ridicare

Imobilizați vehiculul:

1. Blocați roțile
2. Acționați frâna de parcare
3. Apăsați butonul P (parcare) pentru a selecta poziția P (parcare)

Puncte de ridicare:

 Puncte de ridicare adecvate

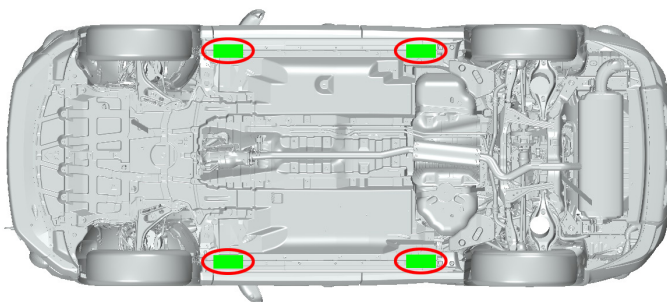

3. Înlăturare pericole / reguli de securitate

1. Apăsați butonul Start/Stop pentru a opri motorul



Apoi scoateți cheia electronică și stați la cel puțin 5 m depărtare de autovehicul

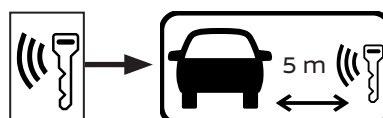

Acces la compartimentul motor

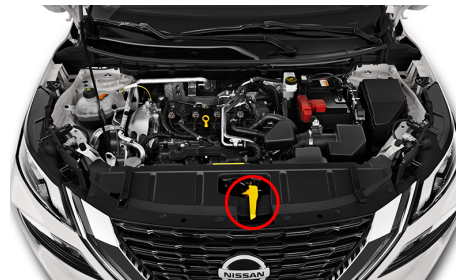

2. Deconectați bateria de 12 volți

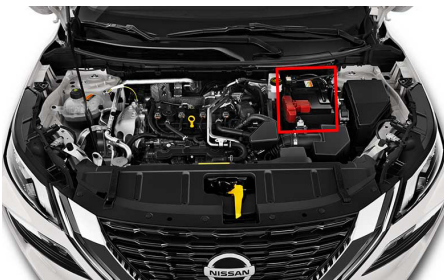
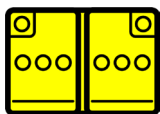

4. Accesul către ocupanți

Oțel de înaltă rezistență în caroserie și uși

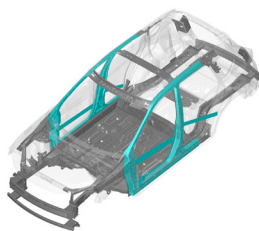

Reglare scaun

Electric



Manual



Ajustarea volanului



Tipuri de sticlă:

- A. Sticlă laminată
- B. Geam securizat



5. Energie stocată / lichide / gaze / solide

	12V				
	R-1234yf 1005 g				
	55L				
	12V Li-ion				

8. Tractare / transport / depozitare

Locație ochiul de remorcare



Locație cârlig față



Locație cârlig spate



Remorcarea

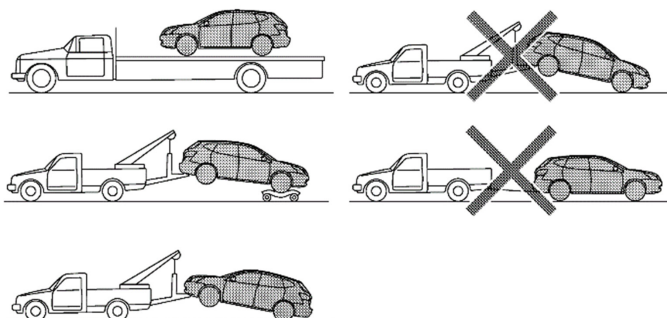

10. Explicarea pictogramelor utilizate

	Îndepărtați cheia inteligentă		Inflamabil
	Simbol de avertizare generală		Periculos pentru sănătatea umană
	Avertisment; temperatură scăzută		Exploziv
	Componentă a sistemului de aer condiționat		Coroziv
	Vehicul alimentat cu combustibil din grupa de fluide 1		Capotă